

Nacho Cheese Warmer

Part No. 38409

Instruction Manual

Model #2365, #2365LS and #2365EX







 **GOLD MEDAL**®



FUNFOOD EQUIPMENT & SUPPLIES



Cincinnati, OH 45241-4807 USA



SAFETY PRECAUTIONS

	 DANGER
	<p>Machine must be properly grounded to prevent electrical shock to personnel. Failure to do so could result in serious injury, or death. DO NOT immerse any part of this equipment in water. DO NOT use excessive water when cleaning. Keep cord and plug off the ground and away from moisture. Always unplug the equipment before cleaning or servicing. Make sure all machine switches are in the OFF position before plugging the equipment into the receptacle.</p> <p style="text-align: right; font-size: small;">008_051514</p>

	 DANGER
	<p>Improper installation, adjustment, alteration, service, or maintenance can cause property damage, injury, or death. Any alterations to this equipment will void the warranty and may cause a dangerous condition. NEVER make alterations to this equipment. Read the Installation, Operating, and Maintenance Instructions thoroughly before installing, servicing, or operating this equipment.</p> <p style="text-align: right; font-size: small;">014_051514</p>



	 WARNING
	<p>To avoid burns, DO NOT touch heated surfaces. DO NOT place or leave objects in contact with heated surfaces.</p> <p style="text-align: right; font-size: small;">009_010914</p>



	 WARNING
	<p>ALWAYS wear safety glasses when servicing this equipment.</p> <p style="text-align: right; font-size: small;">010_010914</p>

	 WARNING
	<p>No user serviceable parts inside. Refer servicing to qualified service personnel.</p> <p style="text-align: right; font-size: small;">011_051514</p>

	 WARNING
	<p>Read and understand operator's manual and all other safety instructions before using this equipment. To order copies of the operator's manual go to gmpopcorn.com or write to Gold Medal Products Co., 10700 Medallion Drive, Cincinnati, OH 45241 USA 1-(800)-543-0862</p> <p style="text-align: right; font-size: small;">022_010914</p>

SAFETY PRECAUTIONS (continued)

	 WARNING
	DO NOT allow direct contact of this equipment by the public when used in food service locations. Only personnel trained and experienced in the equipment operation may operate this equipment. Carefully read all instructions before operation. 012_010914

	 WARNING
	This machine is NOT to be operated by minors. 007_010914

Note: Improvements are always being made to Gold Medal's equipment. This information may not be the latest available for your purposes. It is critical that you call Gold Medal's Technical Service Department at 1-800-543-0862 for any questions about your machine operations, replacement parts, or any service questions. (Gold Medal Products Co. does not assume any liability for injury due to careless handling and/or reckless operation of this equipment.)

INSTALLATION INSTRUCTIONS

Inspection of Shipment

After unpacking, check thoroughly for any damage which may have occurred in transit. Claims should be filed immediately with the transportation company. The warranty does not cover damage that occurs in transit, or damage caused by abuse, or consequential damage due to the operation of this machine, since it is beyond our control (reference warranty in back of manual).

Manual



Read and understand the operator's manual and all other safety instructions before using this equipment. To order copies of the operator's manual go to gmpopcorn.com or write to Gold Medal Products Co., 10700 Medallion Drive, Cincinnati, OH 45241 USA 1-(800)-543-0862.

Electrical Requirements

The following power supply must be provided:

2365 and 2365LS: 120 V~, 300 W, 60 Hz

2365EX: 230 V~, 300 W, 50 Hz

	 DANGER
<p>Machine must be properly grounded to prevent electrical shock to personnel. Failure to do so could result in serious injury, or death. DO NOT immerse any part of this equipment in water. DO NOT use excessive water when cleaning. Keep cord and plug off the ground and away from moisture. Always unplug the equipment before cleaning or servicing. Make sure all machine switches are in the OFF position before plugging the equipment into the receptacle.</p>	
<small>008_051514</small>	

Your electrician must furnish sufficient power for proper machine operation. We recommend this equipment be on a dedicated and protected circuit. Failure to wire properly will void the warranty and may result in damage to the machine. It is Gold Medal Products Co.'s recommendation that this machine be plugged directly into a wall outlet. The use of extension cords is not recommended due to safety concerns, and may cause sacrificed and/or reduced performance. Make sure cord is located to prevent a trip hazard or unit upset.

Before You Plug In Machine

1. Make sure all machine switches are in the OFF position before plugging the equipment into the receptacle.
2. Make sure the wall outlet can accept the grounded plugs (where applicable) on the power supply cord.
3. The wall outlet must have the proper polarity. If in doubt, have a competent electrician inspect the outlet and correct if necessary.
4. DO NOT use a grounded to un-grounded receptacle adapter (where applicable).
5. Install the unit in a level position.

OPERATING INSTRUCTIONS



1. Fill water well to the bottom of the “water level” ring.
2. Insert the cheese bowl into the water.
3. Install the cover and ladle into the top of the cheese bowl insert.
4. Plug the unit into the wall socket.
5. Set control knob to 150° F setting.
6. Let cheese heat for 45 minutes (stirring every 15 minutes) before serving.
7. Turn heat control switch to “OFF” position when unit is not in use.

CARE AND CLEANING

	⚠ DANGER
	Unplug the machine before cleaning. Do not immerse the unit in water.

Clean your machine daily. A clean well kept machine is one of the best ways of advertising your product.

Use a mild soap and damp cloth to clean the exterior of the unit.

All utensils and the insert bowl should be cleaned with a sanitizing solution to help prevent contamination from micro-organisms.

LIGHT BULB & SIGN REPLACEMENT

	⚠ DANGER
	Unplug the machine before servicing.

1. Remove the cheese bowl insert from the unit.
2. Remove the water from the machine.
3. Remove the two screws that hold the retaining angle.
4. Slide the sign out from the bottom.
5. Remove the bulb from the socket and replace as necessary.
6. Clean all interior surfaces before re-assembly.
7. Reinstall the sign and retaining angle. Re-install the two screws.

MAINTENANCE INSTRUCTIONS

	⚠ CAUTION
	THE FOLLOWING SECTIONS OF THIS MANUAL ARE INTENDED ONLY FOR QUALIFIED SERVICE PERSONNEL WHO ARE FAMILIAR WITH ELECTRICAL EQUIPMENT. THESE ARE NOT INTENDED FOR THE OPERATOR.

	⚠ WARNING
	Adequate eye protection must be used when servicing this equipment to prevent the possibility of injury.

	⚠ DANGER
	Do NOT immerse the equipment in water. Unplug your machine before servicing.

HEAT ELEMENT & THERMOSTAT REPLACEMENT

1. Remove the cheese bowl insert.
2. Turn the unit upside down.
3. Remove the screws from the bottom of the unit. It is not necessary to remove the rubber feet.
4. Unfasten the thermostat screw and the two screws from the heating element.
5. Disconnect the wires from the thermostat and heating element.
6. Replace unserviceable parts and rewire as shown in the wiring diagram.

ORDERING SPARE PARTS

1. Identify the desired part by checking it against the photos, illustrations, and/or the parts list.
2. When ordering, please include part number, part name, and quantity desired.
3. Please include your model name and machine serial number (located on the machine nameplate) with your order.
4. Address all parts orders to:

Parts Department
Gold Medal Products Co.
10700 Medallion Drive
Cincinnati, Ohio 45241-4807

or, place orders at:

(513) 769-7676
Fax: (513) 769-8500
E-mail: goldme19@eos.net

CABINET ASSEMBLY

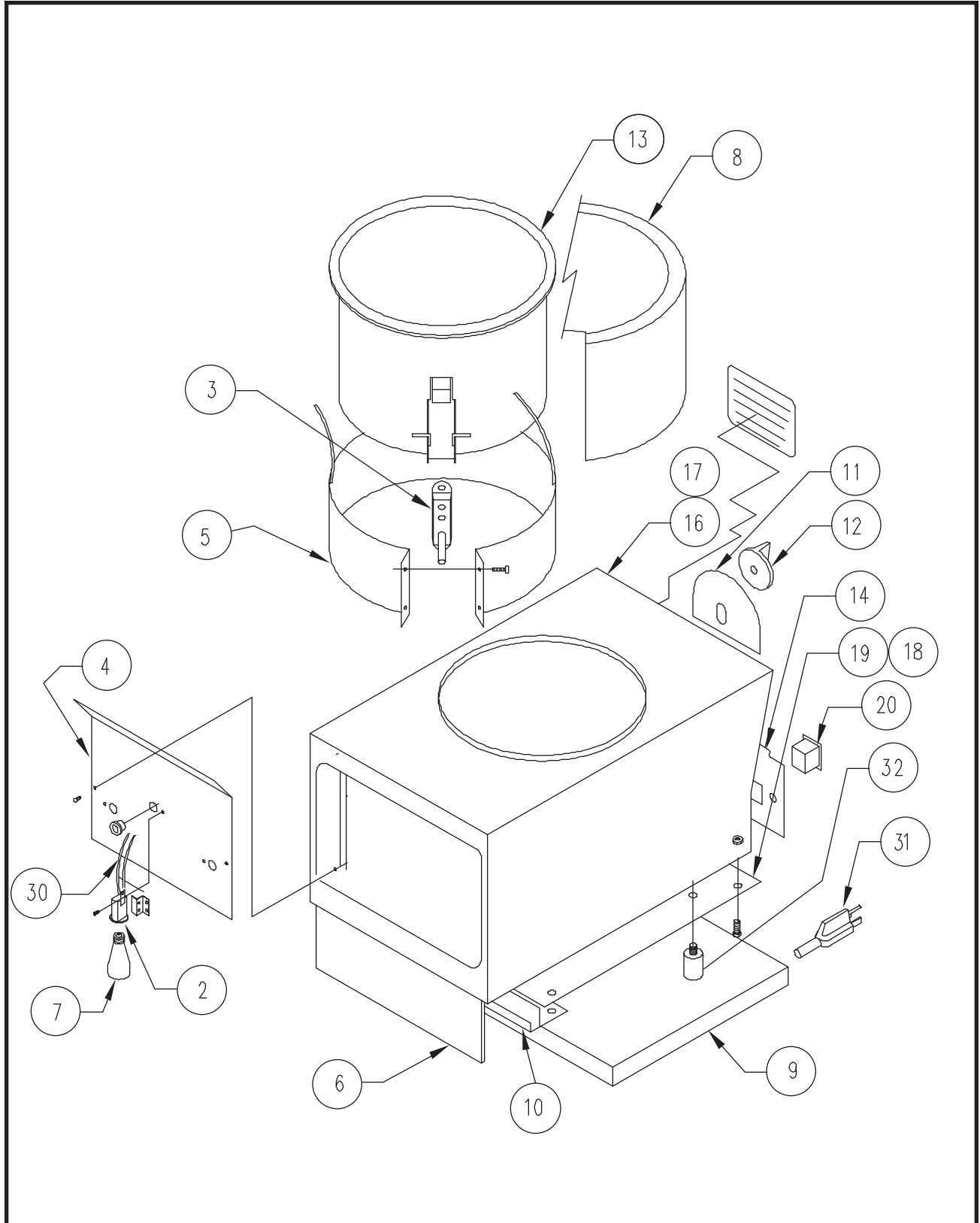

CABINET ASSEMBLY PARTS LIST

Item No.	Model #2365 Part No.	Model #2365LS Part No.	Model #2365EX Part No.	Description
1	22038	22038	42369	Lead In Cord
2		38077		Socket, Lamp Holder
3	38227	38227	38227	Thermostat
4		38272		Light Baffle
5	38279	38279	38208	Tank Heat Element
6		38284		Sign Cover
7		38291		Lamp, 6 Watt White
8	38294	38294	38294	Insulation Wrap
9	38295	38295	38295	Insulation Bottom
10		38297		Retaining Angle
11	38303	38303	38303	Temperature Scale
12	38389	38389	38389	Knob, Heat Control
13	38417	38417	38417	Well Body, Welded Assembly
14	38419	38419	38419	Panel, Control
15	38420	38420	38420	Label, Fill to Line (not shown)
16		38421		Lighted Cabinet, Welded Assembly
17	38403		38403	Unlighted Cabinet, Welded Assembly
18		38423		Bottom Cover, Lighted
19	38418		38418	Bottom Cover, Unlighted
20	42532	42532	40328	Switch, Rocker
21	40353	40353	40353	Wire Nut, Black
22	42828	42828	42828	Sheet Metal Screw
23	47010	47010	47010	Label, Safe
24	47300	47300	47300	Tinnerman Fastener
25	74119	74119	74119	Warning, Disconnect Power
26	n/a	n/a	n/a	
27	76026	76026	76026	Strain Relief, Cord
28		82189		Label, Max. Lamp
29	87149	87149	87149	Label, Caution Disconnect
30		87223		Sleeving, Fiberglass
31	87247	87247	87247	Bumper, Headed Screw

WIRING DIAGRAM - Model 2365

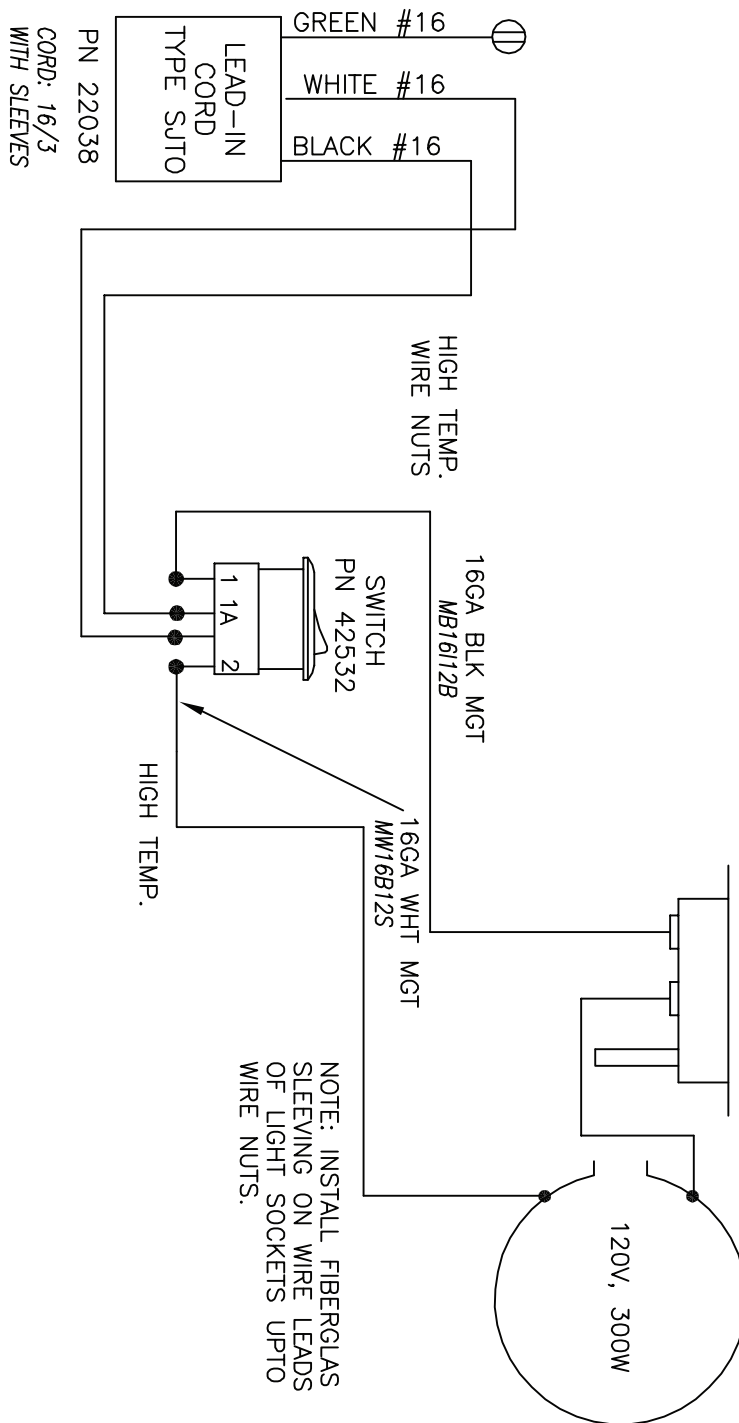

WIRING DIAGRAM - Model 2365LS

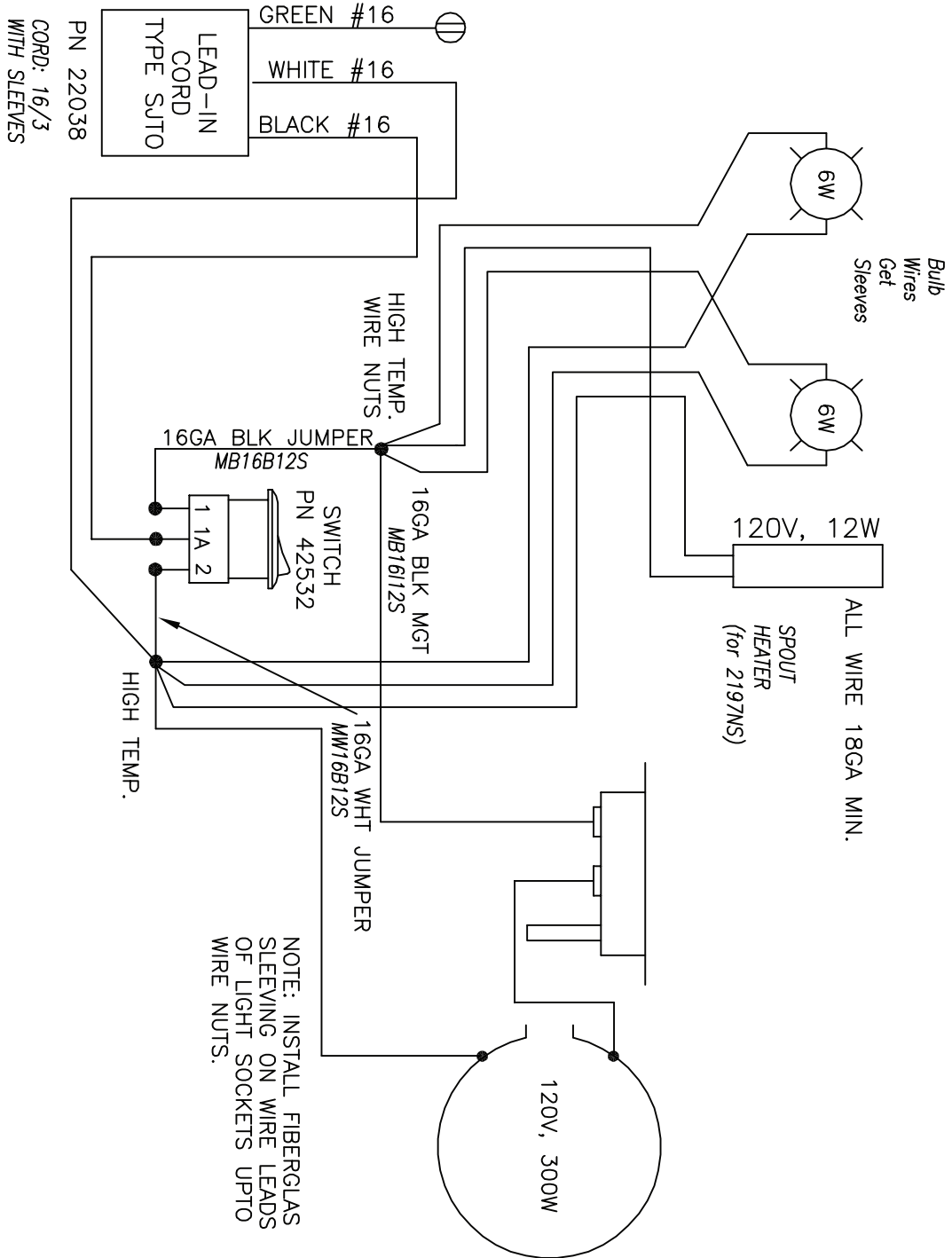

WIRING DIAGRAM - Model 2365EX

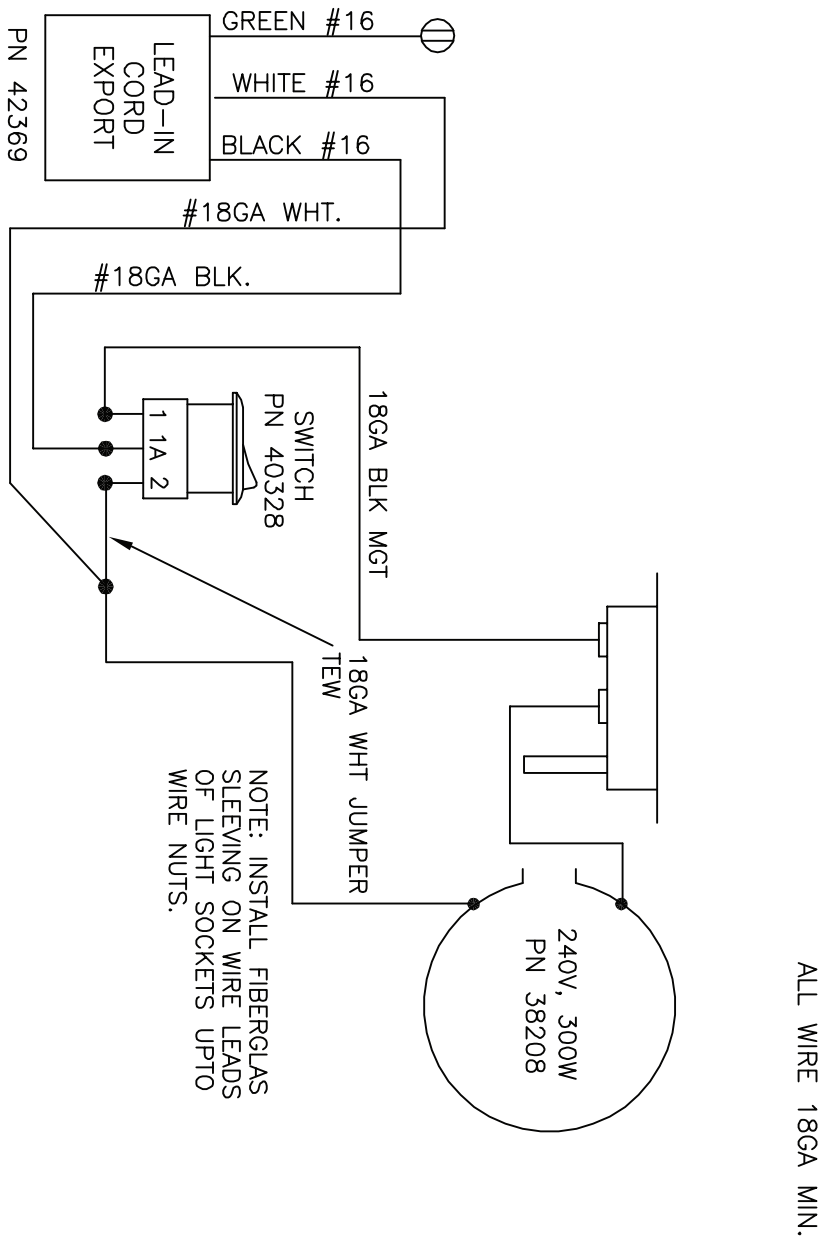

WARRANTY

Gold Medal Products Co. warrants to the original purchaser each item of its manufacture to be free of defects in workmanship and material under normal use and service. Gold Medal Products Co.'s obligation under this warranty is limited solely to repairing or replacing parts, f.o.b. Cincinnati, Ohio, which in its judgment are defective in workmanship or material and which are returned, freight prepaid, to its Cincinnati, Ohio factory or other designated point. Except for "Perishable Parts" on specific machines, the above warranty applies for a period of two (2) years from the date of original sale to the original purchaser of equipment when recommended operating instructions and maintenance procedures have been followed. These are packed with the machine. Parts warranty is two (2) years, labor is six (6) months.

THIS WARRANTY IS IN LIEU OF ALL OTHER WARRANTIES EXPRESSED OR IMPLIED, AND OF ALL OTHER OBLIGATIONS OR LIABILITIES ON OUR PART, INCLUDING THE IMPLIED WARRANTY OF MERCHANTABILITY. THERE ARE NO WARRANTIES WHICH EXTEND BEYOND THE DESCRIPTION ON THE FACE HEREOF. In no event shall Gold Medal Products Co. be liable for special, incidental or consequential damages. No claim under this warranty will be honored if the equipment covered has been misused, neglected, damaged in transit, or has been tampered with or changed in any way. No claim under this warranty shall be honored in the event that components in the unit at the time of the claim were not supplied or approved by Gold Medal Products Co. This warranty is effective only when electrical items have been properly attached to city utility lines only at proper voltages. This warranty is not transferable without the written consent of Gold Medal Products Co.

The term "Original Purchaser" as used in this warranty shall be deemed to mean that person, firm, association, or corporation who was billed by the GOLD MEDAL PRODUCTS CO., or their authorized distributor for the equipment.

THIS WARRANTY HAS NO EFFECT AND IS VOID UNLESS THE ORIGINAL PURCHASER FIRST CALLS GOLD MEDAL PRODUCTS CO. AT 1-800-543-0862 TO DISCUSS WITH OUR SERVICE REPRESENTATIVE THE EQUIPMENT PROBLEM, AND, IF NECESSARY, FOR INSTRUCTIONS CONCERNING THE REPAIR OR REPLACEMENT OF PARTS.

NOTE: This equipment is manufactured and sold for commercial use only.



GOLD MEDAL[®] PRODUCTS CO.

10700 Medallion Drive, Cincinnati, Ohio 45241-4807 USA

gmppopcorn.com

Phone: (800) 543-0862 Fax: (800) 542-1496
(513) 769-7676 (513) 769-8500

© 2014 – The text, descriptions, graphics, layout, and other material in this publication are the exclusive property of Gold Medal Products Co. and shall not be used, copied, reproduced, or published in any fashion, including website display, without its express written consent.